

Powdercoated steel forms

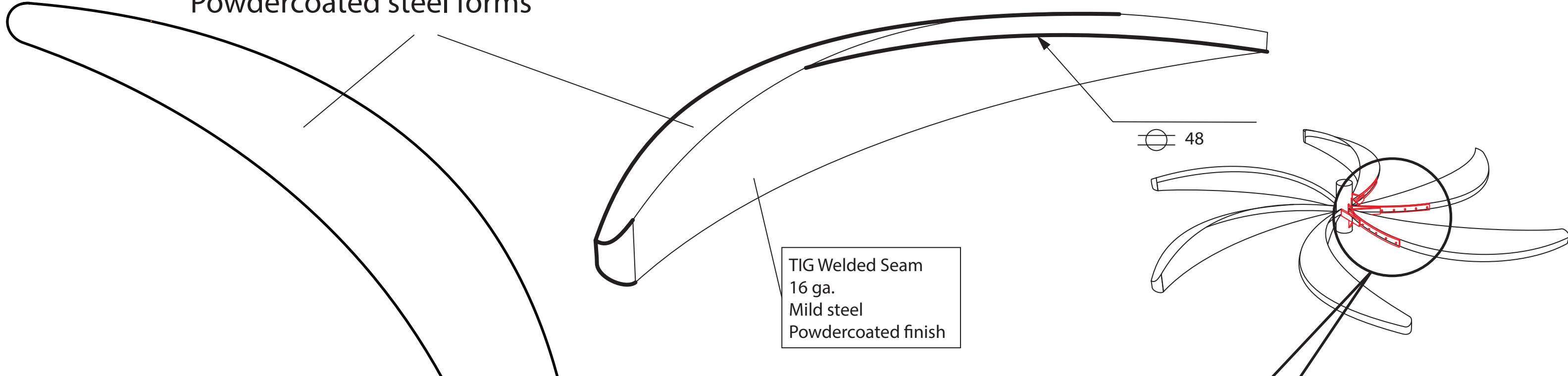

48

TIG Welded Seam  
16 ga.  
Mild steel  
Powdercoated finish

(5) 1/4" SS screws and lock nuts

1/4" SS plate 1" wide

Center pipe  
O.D. 3" schedule 40  
SS 316L

1/4" 1 TIG  
G

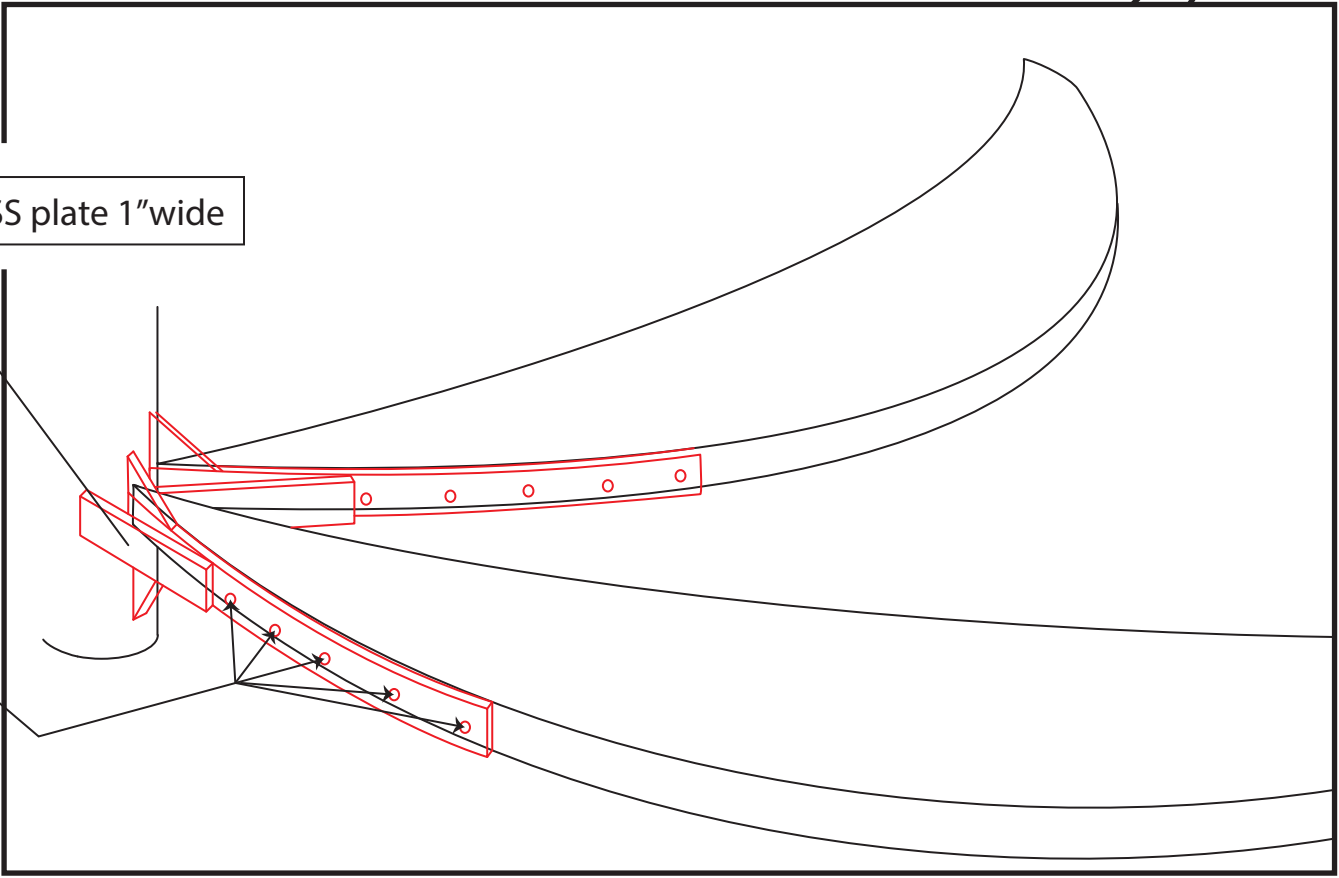



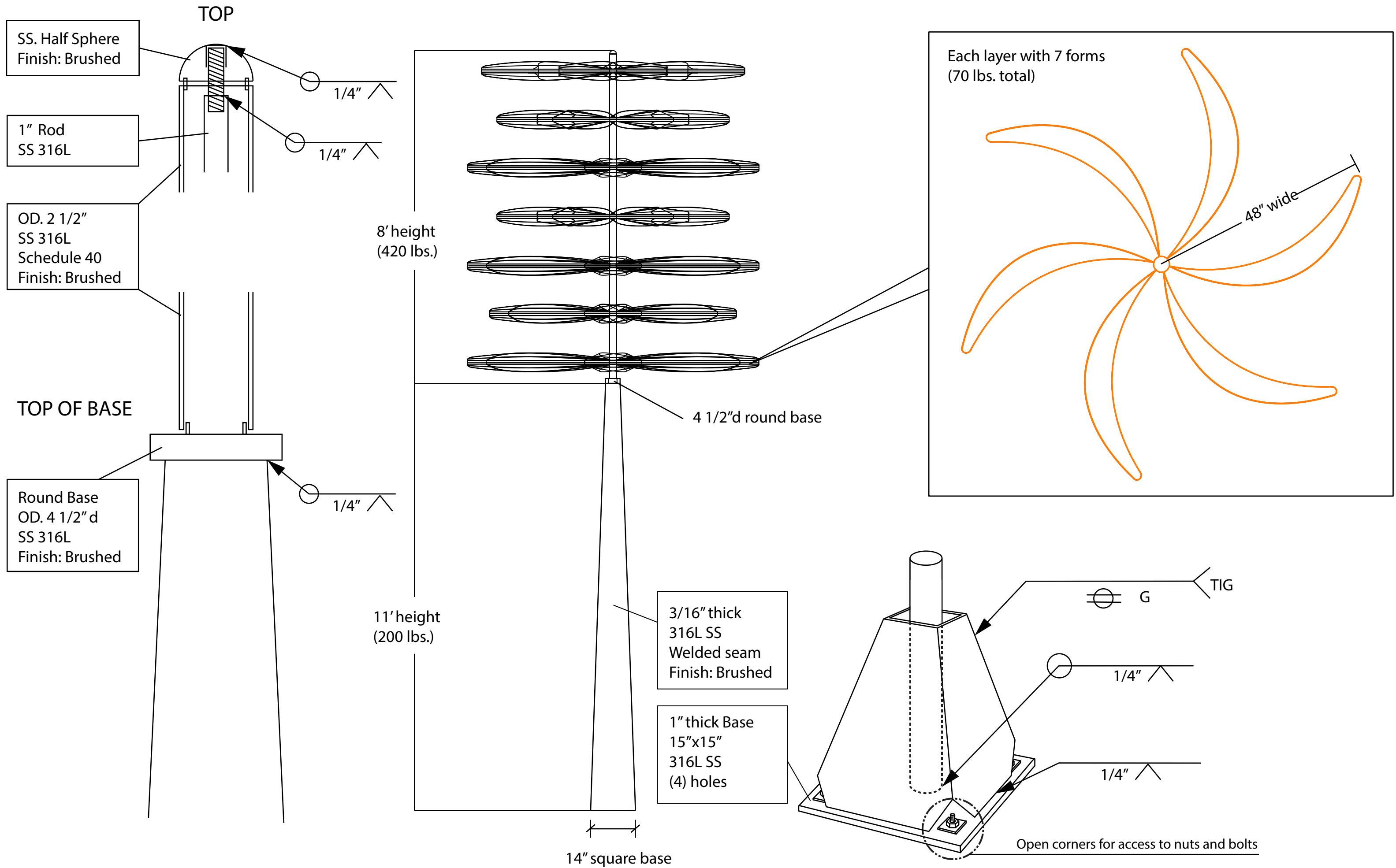

SS. Half Sphere  
Finish: Brushed

1" Rod  
SS 316L

OD. 2 1/2"  
SS 316L  
Schedule 40  
Finish: Brushed

TOP OF BASE

Round Base  
OD. 4 1/2" d  
SS 316L  
Finish: Brushed

3/16" thick  
316L SS  
Welded seam  
Finish: Brushed

1" thick Base  
15"x15"  
316L SS  
(4) holes

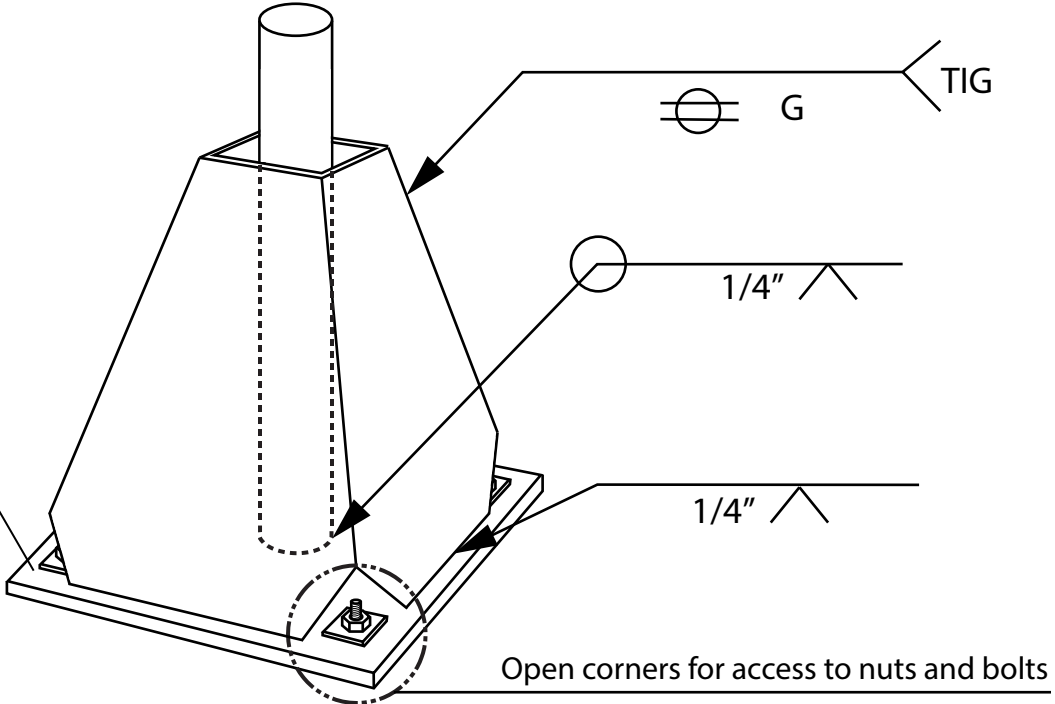
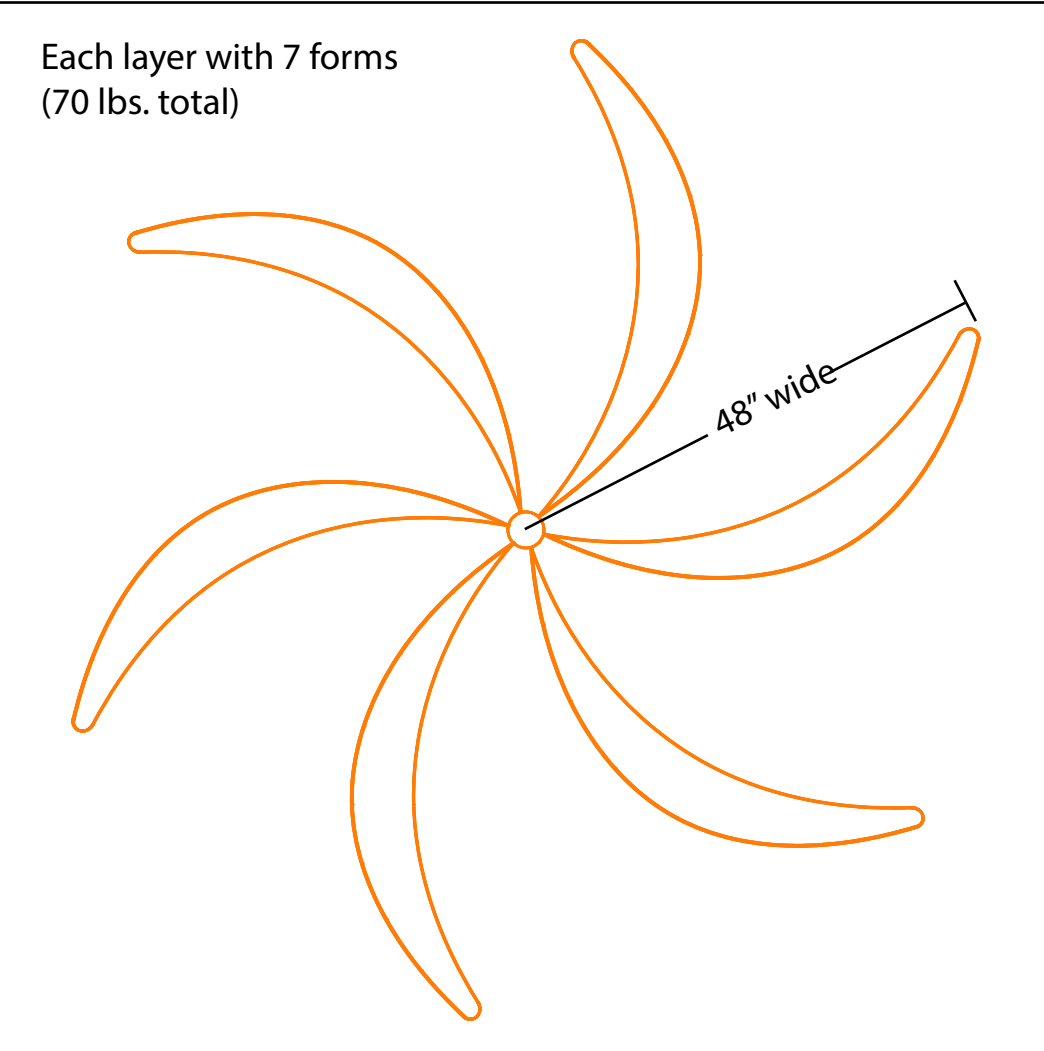



# Sculpture Location

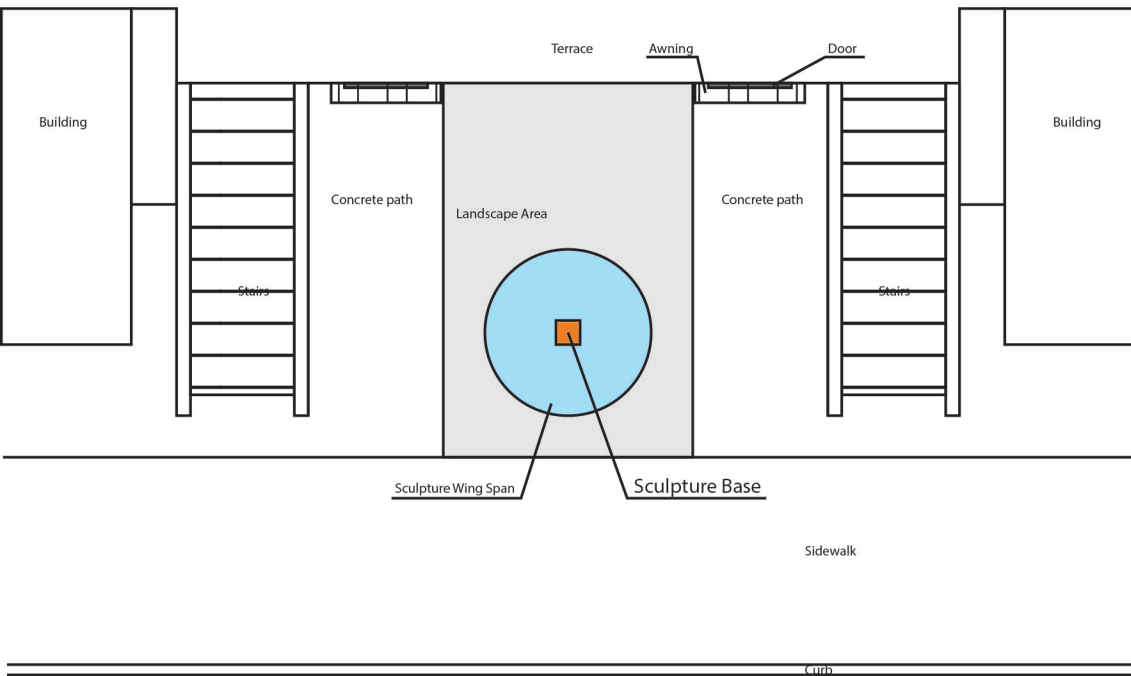

S. Delaware Street

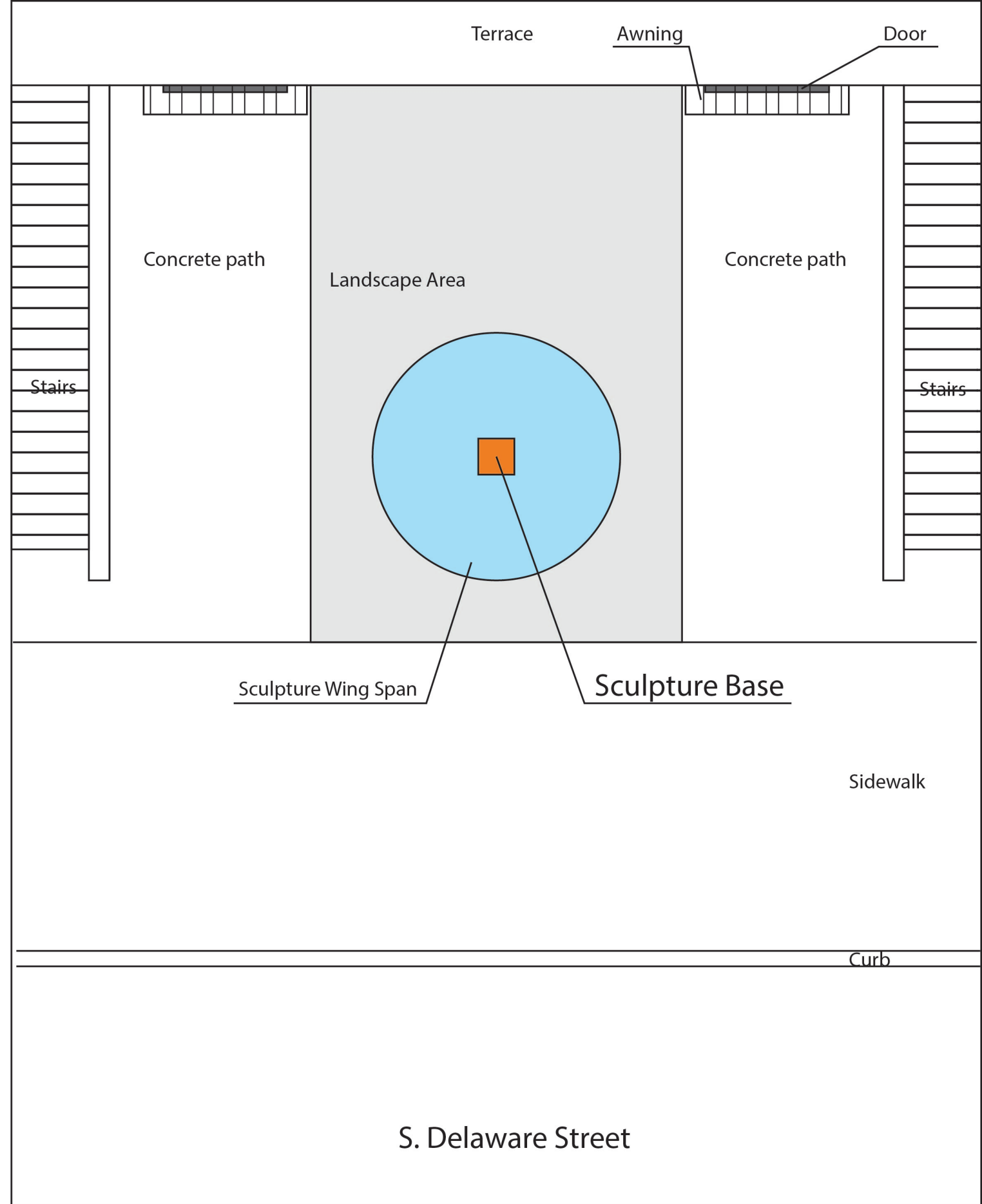

S. Delaware Street